

BANGOR LED SPHERE LANTERN



This LED fitting is IP65 rated and is manufactured with a clear polycarbonate sphere with coated upper canopy in Black.
The aluminium louvers and LED technology provides a controlled distribution pattern and minimises glare.
The Bangor sphere has easy access to the LED driver via removing bowl.
This luminaire is typically mounted at heights of 4 - 6 meters.

Features

- ✓ Effective light distribution
- ✓ Achieves energy savings of up to 75% in comparison to traditional solutions
- ✓ Low CO2 emissions
- ✓ Low maintenance
- ✓ Long life span > 100,000hrs
- ✓ High Quality - UK Made

Applications

- ✓ Car Parks
- ✓ Retail Parks
- ✓ Walk Ways
- ✓ Parks & Gardens
- ✓ Security
- ✓ Amenity Areas

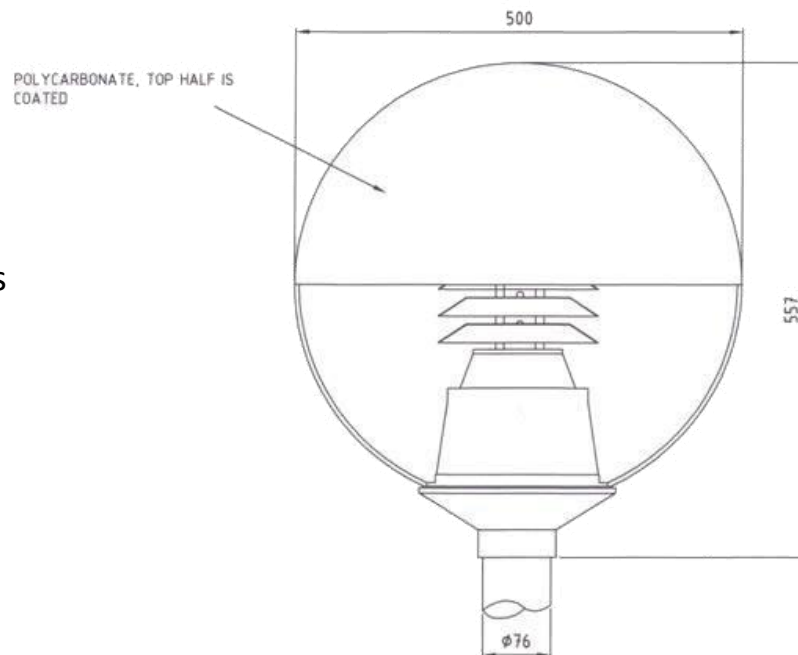

Specifications

Product Code	Bangor
Power Consumption LED's	27.36 Watts
Power Consumption Driver	1.99 Watts
Total Power Consumption	29.35 Watts
Nominal Voltage	200 –240Vac
Input Frequency	50 –60Hz
Light Source	1.14 W High Power LED
LED QTY	24
Total LED Output	3960lm
Efficiency (Typ.)	88%
LED Colour	Cool White
Colour Temp (K)	5400 -6300 degrees K(Standard)
CRI	Ra>70
LED Lifespan	100,000 Hours
Operating Temperature	-30 degrees C to + 50 degrees C
Working Humidity	0 ~ 95%
Turn on time	100ns
Product Size (mm)	Ø 500mm
Unit colour	Capped sphere in black
Net Weight	6 Kg
Mounting	76mm dia column spigot
Protection Rate	IP65
Warranty	3 Years
Certification	RoHS, CE